

Sterlco® TC120 SERIES

Water Temperature Control Unit

Technical Specifications

The Sterling Sterlco® TC120 Series Water Temperature Control Units provide highly accurate control for production applications requiring a continuous supply of temperature-controlled water.

Innovative design promotes turbulent water flow to maximize heat transfer performance. High flow pumps with 32°F to 250°F (0°C to 121°C) setpoint operating range. The cast-and-flange design reduces connection points by 40% while including high-efficiency pumps that offer higher flow rates at lower pressures. These highly efficient products maintain temperatures to within 1°F of setpoint, allowing for tighter temperature control and improved throughput.

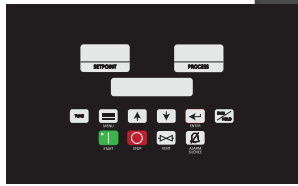

Optional
Advanced
M2C Controller

HISTORICAL RELIABILITY

- Over 60 years of TCU design, engineering, and knowledge

CUSTOMIZABLE

- Full list of features & options
- Customize to specific application needs
- 2 Controller options available

DURABLE

- Robust design under NEMA 12 standards
- Highest quality components
- Larger, more durable casters

Features

Standard Features

- Compact design with easy-access side panels for rapid maintenance
- Programmable auto vent sequence to automatically vent air from the system at start-up
- Independent high temperature safety thermostat to protect from heater overload
- Motor branch circuit overcurrent/overlead protection
- Integrated cooling solenoid valves for efficient unit cooling
- Forward-facing liquid-filled To and From Process pressure gauges
- 9kW dual circuit immersion heater with IEC contactors

- Operator friendly PID temperature controller with Process and Setpoint LED readouts and straightforward unit performance data
- Graphic control panel with indicator and warning status lights
- Adjustable low supply water pressure switch; 16 psig (1.1 bar)
- 150 psig (10.3 bars) pressure relief valve
- SICB/carbon pump seal to maximize pump life
- 0.75" water supply connection, 1.5" process connections; valve size matches drain size
- Quick cool for rapid unit cooling
- 1 year warranty on parts and labor at the factory
- 3 year warranty on controller

Optional Features

- Advanced M2C Controller
- 12 kW, 18 kW, or 24 kW heater options
- Maintained START/STOP switch
- General fault audio/visual alarm to alert operators of unit issues
- Pressure regulator/relief valve for water supply
- Auto system water purge
- Y-strainer to protect unit from high particulate fluid
- 300°F (149°C) operations, includes silicon carbide/silicon carbide seal (requires 55 psig (379 kPa/3.8 bar) water supply pressure)
- Non-fused lockable rotary through door disconnect

Product Diagrams

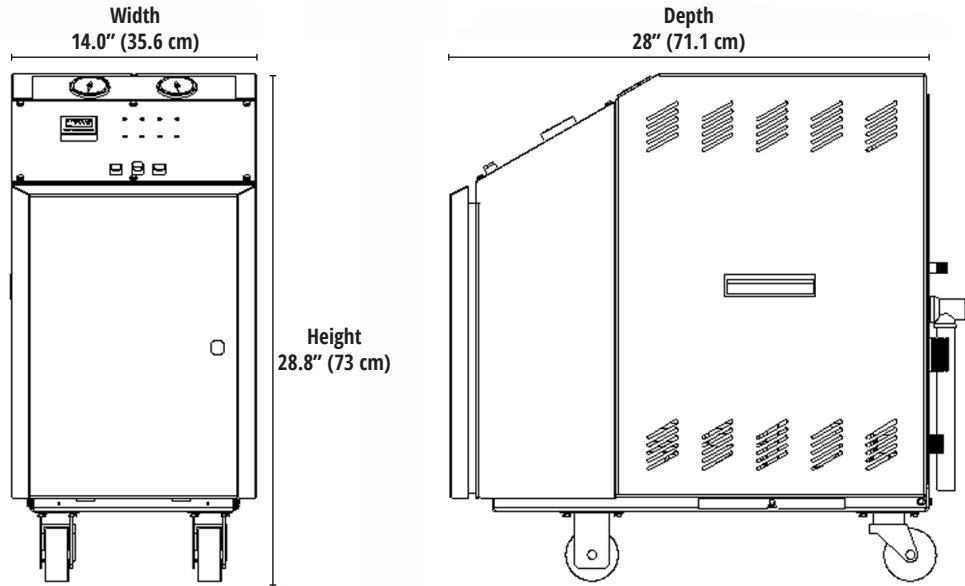

Pump Curves

Charts show flows and pressures that are available for the standard pump options.

Custom pumps available upon request.

Pump HP (kW)	Flow GPM (LPM)	Pressure PSIG (bar)
0.75 (.56)	30 (114)	25 (1.72)
1.0 (0.75)	35 (133)	30 (2.07)
2.0 (1.5)	50 (189)	30 (2.07)
3.0 (2.24)	60 (227)	40 (2.76)
5.0 (3.76)	75 (284)	54 (3.72)
7.5 (5.6)	90 (341)	63 (4.34)

